

REV. P

UNLESS OTHERWISE NOTED  
 TOLERANCES ARE:  
 ONE PLACE DECIMALS ±.1[2.54] THREE PLACE DECIMALS ±.005[.13]  
 TWO PLACE DECIMALS ±.01[.25] FOUR PLACE DECIMALS ±.0010[.025]

TITLE: .050 x .050 DUAL TERMINAL ASSEMBLY MIXED TECHNOLOGY  
 DWG NO: FTSH-1XX-XX-XX-MT-XX  
 SHEET 1 OF 1

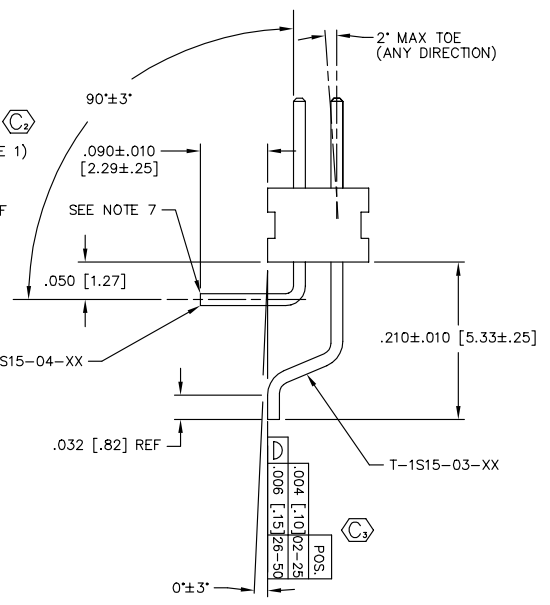
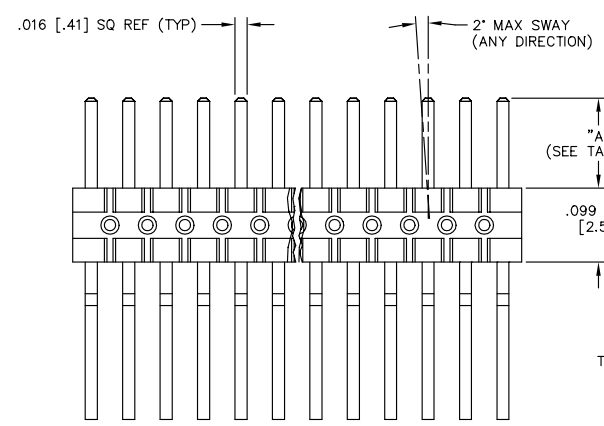
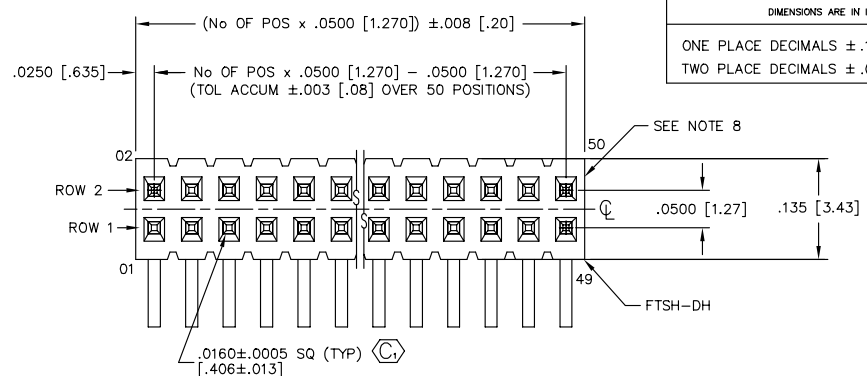

FTSH-1XX-XX-XX-MT-XX

No OF POS. PER ROW  
 -02 THRU -50  
 (SEE NOTE 2 & 5)

PACKAGING  
 -TR: TAPE AND REEL  
 DOUBLE MIXED TECHNOLOGY

LEAD STYLE

-01: "A" = .120 [3.05]  
 -02: "A" = .075 [1.91]  
 -04: "A" = .150 [3.81]  
 (SEE TABLE 1 FOR TERMINAL USAGE)

PLATING

-L: LIGHT SELECTIVE  
 (USE T-1S15-04-L & T-1S15-03-L)  
 -F: FLASH SELECTIVE  
 (USE T-1S15-04-F & T-1S15-03-F)  
 -S: SELECTIVE GOLD  
 (USE T-1S15-04-S & T-1S15-03-S)  
 -H: HEAVY GOLD  
 (USE T-1S15-04-H & T-1S15-03-H)  
 -SM: HEAVY SELECTIVE GOLD, MATTE TIN TAIL  
 (USE T-1S15-04-S & T-1S15-03-S)  
 -LM: LIGHT SELECTIVE GOLD, MATTE TIN TAIL  
 (USE T-1S15-04-L & T-1S15-03-L)  
 -FM: FLASH SELECTIVE GOLD, MATTE TIN TAIL  
 (USE T-1S15-04-F & T-1S15-03-F)  
 -TM: MATTE TIN (USE T-1S15-04-T & T-1S15-03-T)

- NOTES:
1. TERMINALS TO BE SHEARED TO MEET DIMENSION SPECIFICATION.
  2. PARTS MAY BE CUT TO POSITION.
  3. MINIMUM PUSHOUT FORCE: .5 LB.
  4. MAXIMUM TOP / BOTTOM BOW: .004 [.10].
  5. SEE PACKAGING TABLE 2.
  6. Ⓞ REPRESENTS A CRITICAL DIMENSION
  7. .002 MAX BURR ALLOWED.
  8. .015 MAX CUT FLASH ALLOWED.
  9. PINS 2 TO BE FLUSH TO .003 ABOVE OR BELOW LINE MADE BY BODY.

TABLE 1

LEAD STYLE	"A"	ROW 1	ROW 2
-01	.120±.005 [3.05±.13]	T-1S15-04-XX	T-1S15-03-XX
-02	.075±.005 [1.91±.13]	T-1S15-04-XX	T-1S15-03-XX
-04	.150±.005 [3.81±.13]	T-1S15-04-XX	T-1S15-03-XX

TABLE 2

LEAD STYLE	NO. OF POS	PACKAGING
-01	-02 THRU -04	TAPE & REEL
-01	-05 THRU -50	PT-1-24-07-15
-02	-02 THRU -05	TAPE & REEL
-02	-06 THRU -50	PT-1-24-07-15
-04	-02 THRU -03	TAPE & REEL
-04	-04 THRU -50	PT-1-24-03-17

PT-1-24-07-15  
 (-01, -02 LEAD STYLE)  
 TUBE TO USE (2) TP-03

PT-1-24-03-17  
 (-04 LEAD STYLE)  
 TUBE TO USE (2) TP-09

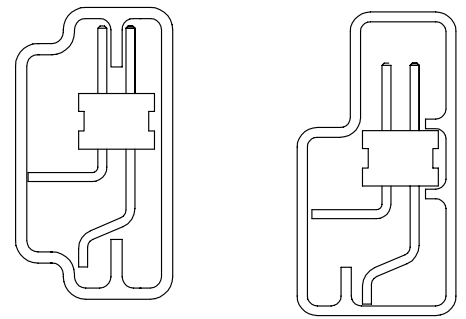

**PROPRIETARY NOTE**  
 THIS DOCUMENT CONTAINS INFORMATION CONFIDENTIAL AND PROPRIETARY TO SAMTEC INC. AND SHALL NOT BE REPRODUCED OR TRANSFERRED TO OTHER DOCUMENTS OR DISCLOSED TO OTHERS OR USED FOR ANY PURPOSE OTHER THAN THAT FOR WHICH IT WAS OBTAINED WITHOUT THE EXPRESSED WRITTEN CONSENT OF SAMTEC INC.

PLOT SCALE: 1=1.3125/ DIM SCALE: 1=100

**samtec**  
ENHANCED ASSEMBLY

520 PARK EAST BLVD. NEW ALBANY, INDIANA 47150  
 PHONE (812) 944-6733 P.O. BOX 1147  
 CODE 55322

MADE BY: PURVIS 07-29-96 FTSH-1XX-XX-XX-MT-XX  
 SHEET 1 OF 1