

S'S6S'S8S'S8

G97H-CB'5'5'
G75@9' : %

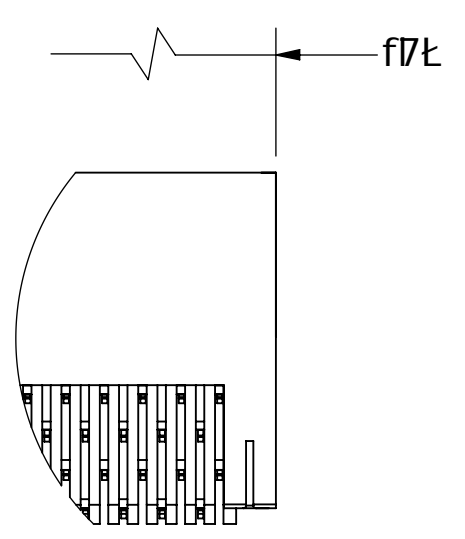

S'S6S'S'8S'SB

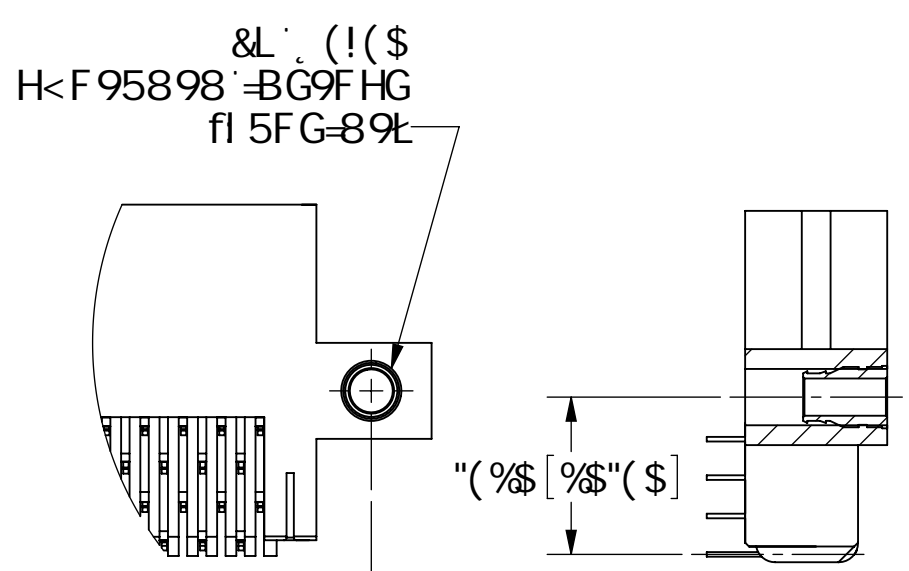

S'S6S'S'8S'S5

ACI BH-B; GHM@9G
fG99'D5; 9' : CF'588-H-CB5@ACI BH-B; GHM@9G

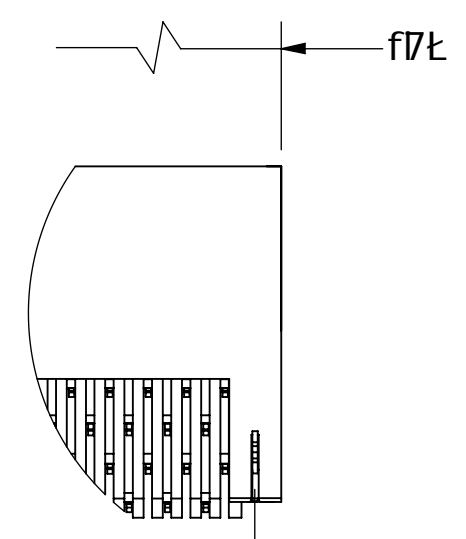

S'S6S'S8S'SF

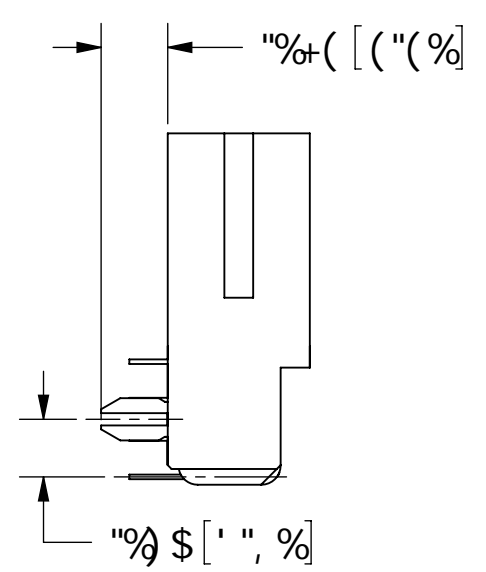

71 GHCA 9F '7CDM



Tc < G'7CAD@5BH

<small>897 F 8HC B</small> 		
D5FHBI A 69F S'S6S'S8S'SzFB<5zB<6L		
<small>GND</small> 7	<small>8K ; "BC"</small> ÔFEEJF	<small>F9J</small> Ô
<small>G7 5 @. ' & . %</small>		<small>G< 99H&C : "</small>

PART NUMBER	NO OF POSITIONS	A±.005[0.13]		B±.005[0.13]		C±.015[0.38]		D±.010[0.25]		E±.020[0.51]		F±.010[0.25]	
		IN	MM	IN	MM	IN	MM	IN	MM	IN	MM	IN	MM
B05D	5	0.200	5.08	0.300	7.62	0.490	12.45	0.776	19.71	1.090	27.69	0.350	8.89
B06D	6	0.250	6.35	0.350	8.89	0.540	13.72	0.826	20.98	1.140	28.96	0.400	10.16
B09D	9	0.400	10.16	0.500	12.70	0.690	17.53	0.976	24.79	1.290	32.77	0.550	13.97
B10D	10	0.450	11.43	0.550	13.97	0.740	18.80	1.026	26.06	1.340	34.04	0.600	15.24
B13D	13	0.600	15.24	0.700	17.78	0.890	22.61	1.176	29.87	1.490	37.85	0.750	19.05
B14D	14	0.650	16.51	0.750	19.05	0.940	23.88	1.226	31.14	1.540	39.12	0.800	20.32
B15D	15	0.700	17.78	0.800	20.32	0.990	25.15	1.276	32.41	1.590	40.39	0.850	21.59
B20D	20	0.950	24.13	1.050	26.67	1.240	31.50	1.526	38.76	1.840	46.74	1.100	27.94
B22D	22	1.050	26.67	1.150	29.21	1.340	34.04	1.626	41.30	1.940	49.28	1.200	30.48
B25D	25	1.200	30.48	1.300	33.02	1.490	37.85	1.776	45.11	2.090	53.09	1.350	34.29
B30D	30	1.450	36.83	1.550	39.37	1.740	44.20	2.026	51.46	2.340	59.44	1.600	40.64
B34D	34	1.650	41.91	1.750	44.45	1.940	49.28	2.226	56.54	2.540	64.52	1.800	45.72
B35D	35	1.700	43.18	1.800	45.72	1.990	50.55	2.276	57.81	2.590	65.79	1.850	46.99
B40D	40	1.950	49.53	2.050	52.07	2.240	56.90	2.526	64.16	2.840	72.14	2.100	53.34
B45D	45	2.200	55.88	2.300	58.42	2.490	63.25	2.776	70.51	3.090	78.49	2.350	59.69
B50D	50	2.450	62.23	2.550	64.77	2.740	69.60	3.026	76.86	3.340	84.84	2.600	66.04
B55D	55	2.700	68.58	2.800	71.12	2.990	75.95	3.276	83.21	3.590	91.19	2.850	72.39
B60D	60	2.950	74.93	3.050	77.47	3.240	82.30	3.526	89.56	3.840	97.54	3.100	78.74
B64D	64	3.150	80.01	3.250	82.55	3.440	87.38	3.726	94.64	4.040	102.62	3.300	83.82
B65D	65	3.200	81.28	3.300	83.82	3.490	88.65	3.776	95.91	4.090	103.89	3.350	85.09
B66D	66	3.250	82.55	3.350	85.09	3.540	89.92	3.826	97.18	4.140	105.16	3.400	86.36
B70D	70	3.450	87.63	3.550	90.17	3.740	95.00	4.026	102.26	4.340	110.24	3.600	91.44
B75D	75	3.700	93.98	3.800	96.52	3.990	101.35	4.276	108.61	4.590	116.59	3.850	97.79
B80D	80	3.950	100.33	4.050	102.87	4.240	107.70	4.526	114.96	4.840	122.94	4.100	104.14
B85D	85	4.200	106.68	4.300	109.22	4.490	114.05	4.776	121.31	5.090	129.29	4.350	110.49
B90D	90	4.450	113.03	4.550	115.57	4.740	120.40	5.026	127.66	5.340	135.64	4.600	116.84
B95D	95	4.700	119.38	4.800	121.92	4.990	126.75	5.276	134.01	5.590	141.99	4.850	123.19
B100D	100	4.950	125.73	5.050	128.27	5.240	133.10	5.526	140.36	5.840	148.34	5.100	129.54
B105D	105	5.200	132.08	5.300	134.62	5.490	139.45	5.776	146.71	6.090	154.69	5.350	135.89
B108D	108	5.350	135.89	5.450	138.43	5.640	143.26	5.926	150.52	6.240	158.50	5.500	139.70
B110D	110	5.450	138.43	5.550	140.97	5.740	145.80	6.026	153.06	6.340	161.04	5.600	142.24
B120D	120	5.950	151.13	6.050	153.67	6.240	158.50	"N" MOUNTING ONLY				6.100	154.94

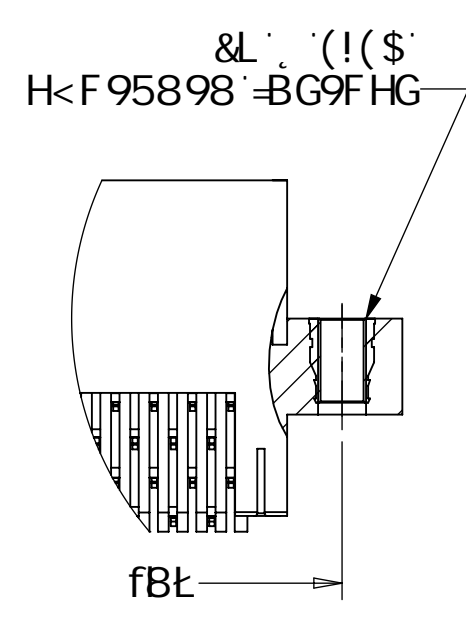
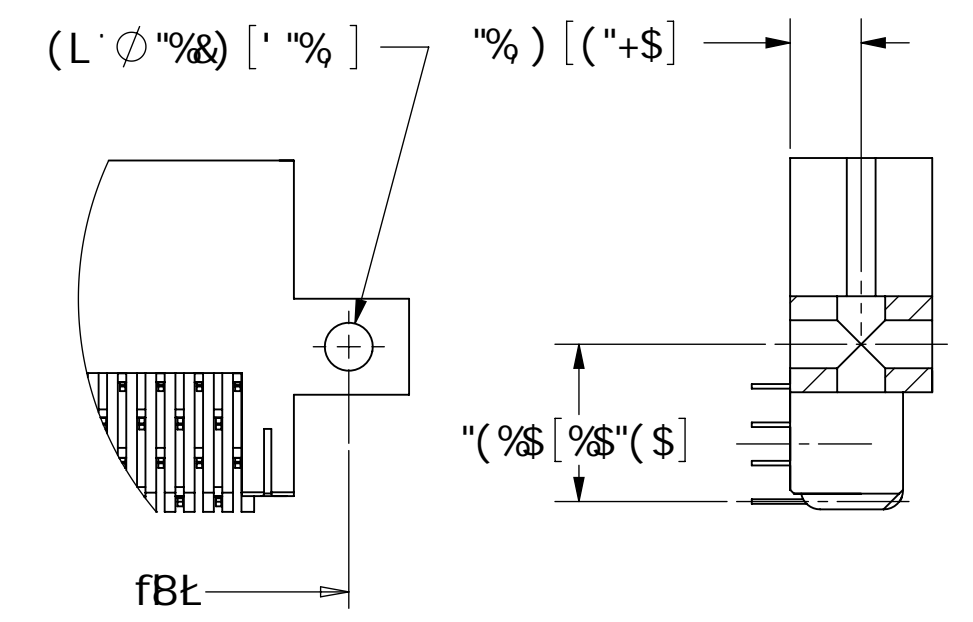

ACI BH-B; GHM@9G

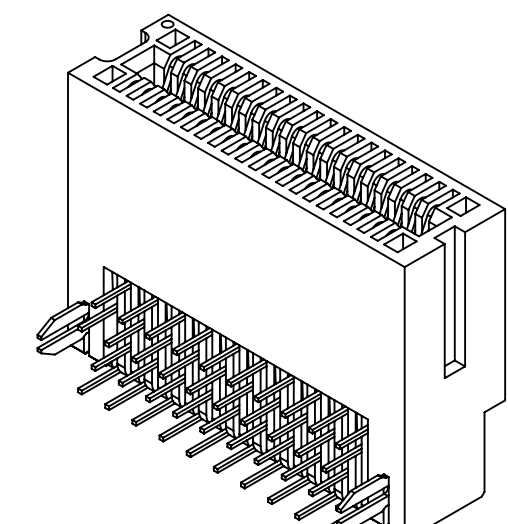

71 GHCA 9F 7CDM



SULLINS CONNECTOR SOLUTIONS	
D5FHBI A 69F	
S'S6S'S8S'SZFB<5Z8<6L	
GNP 8K : "BC"	F9J
7	ÔFEEJF
G7 5@. '(.%	G<99H' 'C : "

