

REVISIONS				
REV.	ECO. NO	DESCRIPTION	DATE	BY
A	1012	ORIGINAL RELEASE	05/01/06	HT
B	1743	UPDATE DWG FORMAT TABULATE MATERIAL INCORPORATING "E" & "H" TO CODING CHART	07/07/08	VJ

PART NUMBER CODING

B **DHH**

MATERIAL (INSULATOR/CONTACT)

- E = BLACK, PBT/PHOSPHOR BRONZE**
OPERATING TEMP: -65°C TO +125°C
PROCESSING TEMP: 260°C FOR 10 SECS MAX
- R = BLACK, PPS/PHOSPHOR BRONZE**
OPERATING TEMP: -65°C TO +125°C
PROCESSING TEMP: 260°C FOR 120 SECS MAX
- G = BLACK, PA9T/PHOSPHOR BRONZE**
OPERATING TEMP: -65°C TO +125°C
PROCESSING TEMP: 260°C FOR 120 SECS MAX
- H = BLACK, PBT/BERYLLIUM COPPER**
OPERATING TEMP: -65°C TO +125°C
PROCESSING TEMP: 260°C FOR 10 SECS MAX
- A = BLACK, PPS/BERYLLIUM COPPER**
OPERATING TEMP: -65°C TO +150°C
PROCESSING TEMP: 260°C FOR 120 SECS MAX
- J = BLACK, PA9T/BERYLLIUM COPPER**
OPERATING TEMP: -65°C TO +150°C
PROCESSING TEMP: 260°C FOR 120 SECS MAX
(CONSULT FACTORY FOR OTHER MATERIALS)

MOUNTING STYLE

- D = FLUSH MOUNTING (PAGE 1)
- N = NO MOUNTING EARS
- T = FLUSH MOUNTING, WITH THREADED INSERTS
- R = METAL BOARDLOCKS

NUMBER OF POSITIONS (CONTACTS PER ROW)

PLATING

- ALL PLATINGS ARE LEAD FREE AND HAVE .000050" NICKEL UNDERPLATE**
- | | |
|-------------------|--------------------------|
| CONTACT SURFACE | TERMINATION |
| B = .000010" GOLD | .000100" PURE TIN, MATTE |
| C = .000030" GOLD | .000100" PURE TIN, MATTE |

NOTES:

1. MATERIALS:
 - A. INSULATOR: SEE PART NUMBER CODING.
 - B. CONTACT: SEE PART NUMBER CODING.
 - C. PLATING: SEE PART NUMBER CODING.
2. THERMAL:
 - A. OPERATING TEMPERATURE: SEE PART NUMBER CODING.
 - B. PROCESSING TEMP: SEE PART NUMBER CODING.
 - C. UL FLAMMABILITY RATING: 94V-0.
3. ELECTRICAL:
 - A. DIELECTRIC WITHSTANDING VOLTAGE: MATED CONNECTOR MUST EXHIBIT NO EVIDENCE OF BREAKDOWN, FLASHOVER, OR DETERIORATION FROM AN APPLIED VOLTAGE OF 300 VAC (VALUE HAS BEEN DE-RATED), RMS 60 Hz WHEN TESTED IN ACCORDANCE WITH MIL-STD-1344, METHOD 3001. DURATION OF APPLICATION SHALL BE 5 SECS MIN.
 - B. INSULATION RESISTANCE (IR): 5,000 MEGOHMS @ 500 VOLTS±10% WHEN TESTED IN ACCORDANCE WITH MIL-STD-1344, METHOD 3003 @ 25°C.
 - C. CONTACT RESISTANCE: 30 MILLIOHM MAX AT RATED CURRENT WHEN TESTED PER MIL-STD-202, METHOD 307 @ 25°C±3°C.
 - D. CURRENT RATING: 1 AMP PER CONTACT.
4. MECHANICAL:
 - A. CONNECTOR IDENTIFICATION: THE PART SHALL BE MARKED WITH A LOT CODE AS A MINIMUM. IF SPACE PERMITS ALSO MARK PART WITH SULLINS WEBSITE, AND PART NUMBER.
 - B. DURABILITY: 500 CYCLES MINIMUM.
 - C. BOARD THICKNESS ACCOMMODATED: .062±.008"
 - D. BOARD INSERTION FORCE: 16 OZ MAX PER CONTACT PAIR WHEN USING A .062" TEST BLADE. INTERNAL INSPECTION TO BE PER SULLIN'S WORK INSTRUCTION W17.3-01.
 - E. BOARD WITHDRAWAL FORCE: 1 OUNCE MINIMUM PER CONTACT PAIR USING .062" PCB.

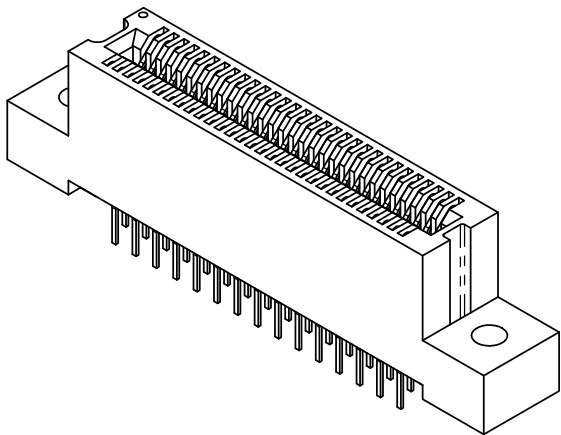

CUSTOMER COPY



RoHS COMPLIANT

UNLESS OTHERWISE SPECIFIED: DIMENSIONS ARE IN INCHES[MM] TOLERANCES: ANGULAR: ± 30' XX ± .02 [508] XXX ± .005 [1270] XXXX ± .0005 [0127] SURFACE FINISH: 63 Ra REMOVE ALL BURRS AND SHARP EDGES .010 MAX		DATE: 05/01/06 NAME: HT	<p>SULLINS CONNECTOR SOLUTIONS</p>							
THE INFORMATION HEREIN CONTAINS PROPRIETARY INFORMATION OF SULLINS ELECTRONICS AND IS NOT TO BE REPRODUCED, USED OR DISCLOSED TO OTHERS FOR ANY PURPOSE EXCEPT AS SPECIFICALLY AUTHORIZED IN WRITING BY AN OFFICER OF SULLINS ELECTRONICS.		DESCRIPTION: EDGE CARD, .050 CC, HP								
INTERPRET DIMENSIONS AND GEOMETRIC TOLERANCING PER: ANSI Y14.5M-1994		<table border="1"> <tr> <td>SIZE: C</td> <td>DWG. NO: C10711</td> <td>REV: B</td> </tr> </table>	SIZE: C	DWG. NO: C10711	REV: B	<table border="1"> <tr> <td colspan="2">PART NUMBER: B DHH</td> </tr> <tr> <td>SCALE: 2:1</td> <td>SHEET 1 OF 3</td> </tr> </table>	PART NUMBER: B DHH		SCALE: 2:1	SHEET 1 OF 3
SIZE: C	DWG. NO: C10711	REV: B								
PART NUMBER: B DHH										
SCALE: 2:1	SHEET 1 OF 3									

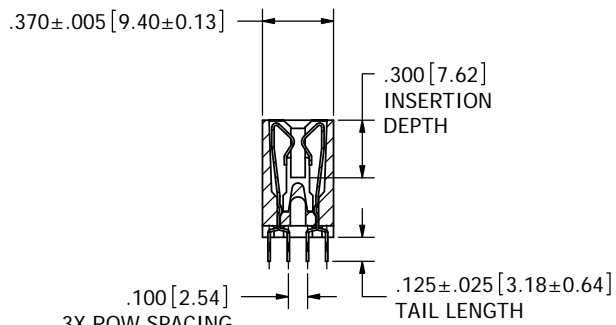
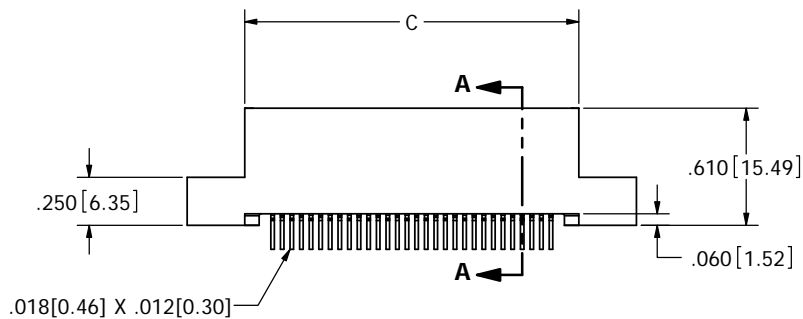
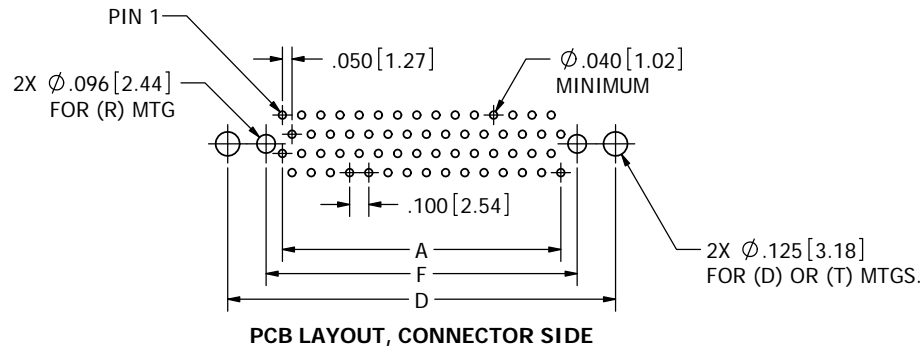
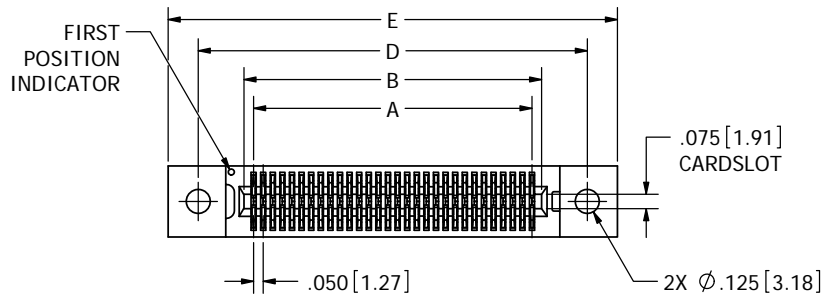

__ B __ DHHD

SECTION A-A

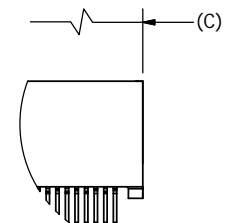

__ B __ DHHN

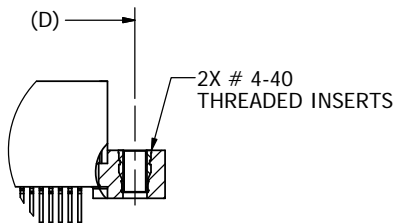

__ B __ DHHT

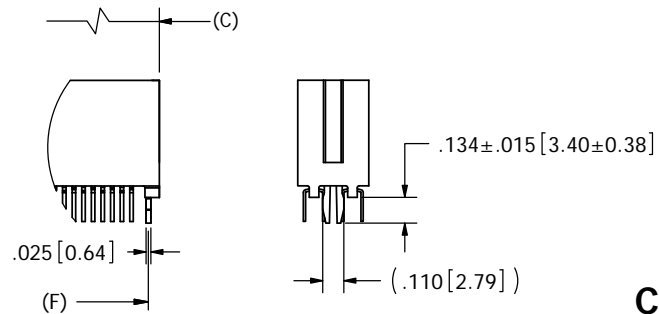

__ B __ DHHR

MOUNTING STYLES

CUSTOMER COPY

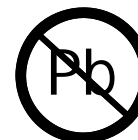

RoHS COMPLIANT

SULLINS CONNECTOR SOLUTIONS	
DESCRIPTION EDGE CARD, .050 CC, HP	
PART NUMBER B __ DHH __	
SIZE C	DWG. NO. C10711
SCALE: 2:1	REV B
SHEET 2 OF 3	

