

FIG. 1

DIMENSIONS ARE IN INCHES UNLESS OTHERWISE NOTED TOLERANCES ARE:  
 ONE PLACE DECIMALS ±.1[.25] THREE PLACE DECIMALS ±.005 [.13]  
 TWO PLACE DECIMALS ±.01[.25] FOUR PLACE DECIMALS ±.0020[.05]  
 ANGLES ± 2°

TITLE: 2mm  
 TERMINAL STRIP  
 ASSEMBLY

DWG NO: TMM-1XX-XX-XX-X-XX-XXX  
 SHEET 1 OF 2

DO NOT SCALE FROM THIS PRINT

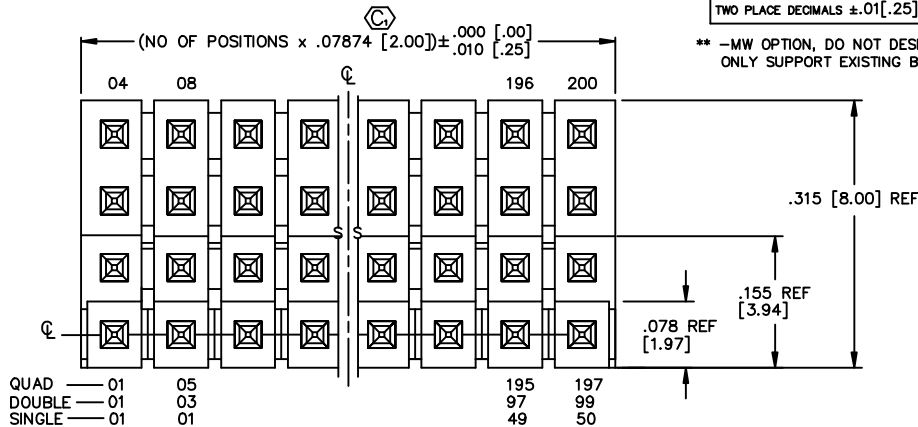

\*\* -MW OPTION, DO NOT DESIGN IN. SAMTEC WILL ONLY SUPPORT EXISTING BUSINESS 2/05/02.

TMM-1XX-XX-XX-X-XX-XXX

NO. OF POSITIONS  
 -01 THRU -50

TERMINAL SPEC  
 SEE TABLE 1

OPTION  
 POLARIZATION  
 SPECIFY POS -XXX AS  
 POS TO BE OMITTED

PLATING SPECIFICATION

- G: GOLD, SPECIFY -G IN TERMINAL SUFFIX -X
- T: TIN, SPECIFY -T IN TERMINAL SUFFIX -X
- S: SELECTIVE, SPECIFY -S IN TERMINAL SUFFIX -X
- L: SELECTIVE, SPECIFY -L IN TERMINAL SUFFIX -X
- F: FLASH SELECTIVE GOLD, SPECIFY -F IN TERMINAL SUFFIX -X
- H: HEAVY GOLD, SPECIFY -H IN TERMINAL SUFFIX -X
- SM: HEAVY GOLD SELECTIVE, MATTE TIN TAIL, SPECIFY -S IN TERMINAL SUFFIX -X
- TM: MATTE TIN SPECIFY -T IN TERMINAL SUFFIX -X
- LM: LIGHT GOLD SELECTIVE, MATTE TIN TAIL SPECIFY -L IN TERMINAL SUFFIX -X
- FM: FLASH GOLD SELECTIVE, MATTE TIN TAIL SPECIFY -F IN TERMINAL SUFFIX -X

- OPTION  
 \*\* -MW: METAL WASHER (-D & -Q BODY SPECS ONLY) (SEE FIG. 2, SHT. 2) (30 POS PER ROW MAX)
- AQ (SEE TABLE 2 PAGE 2)
- RC: RETAINING CLIP FOR IDC USE LTC-09, DOUBLE ROW ONLY, REQUIRES 4 POSITIONS MINIMUM, NOT FOR USE WITH -MW OPTION, SEE NOTES 9 & 10.

- BODY SPECIFICATION
- S: SINGLE (TMM-50-S)
- D: DOUBLE (TMM-50-D)
- Q: QUAD (TMM-50-Q)

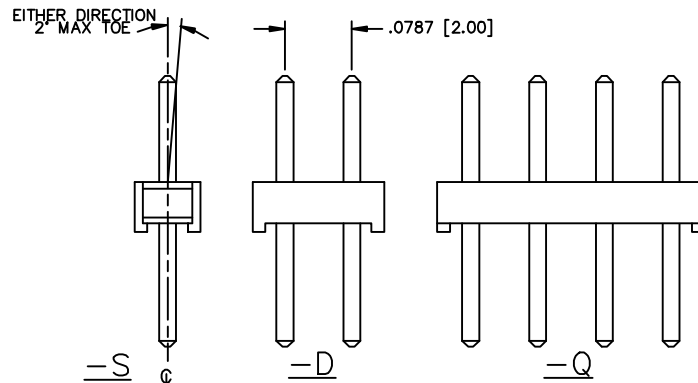
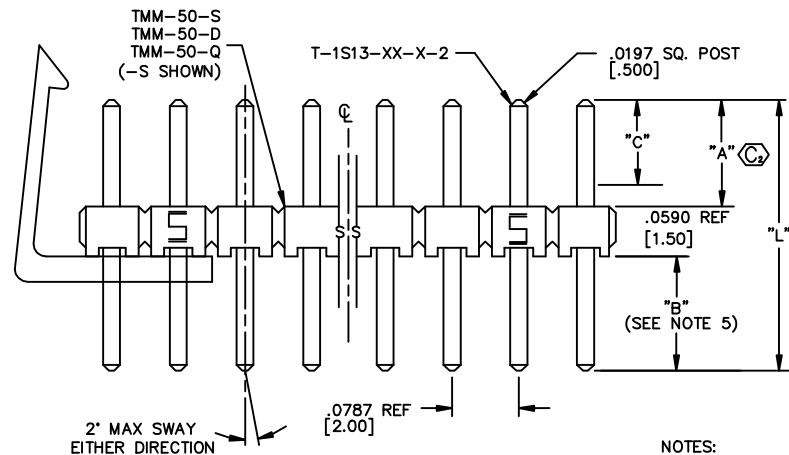

TABLE 1

SUFFIX	TERMINAL	POST "A" IN. [MM]	TAIL "B" IN. [MM]	CONTACT AREA "C" IN. [MM]	STRAIGHT "L" (OVERALL LENGTH)
-01	T-1S13-20-XX-2	.126 [3.20]	.138 [3.50] REF	.100 [2.54] REF	.323 [8.20] REF
-02	T-1S13-20-XX-2	.146 [3.70]	.118 [3.00] REF	.100 [2.54] REF	.323 [8.20] REF
-03	T-1S13-20-XX-2	.158 [4.00]	.106 [2.70] REF	.100 [2.54] REF	.323 [8.20] REF
-04	T-1S13-20-XX-2	.075 [1.90]	.090 ± .010 [2.29 ± .25] (SEE NOTE 5)	.100 [2.54] REF	.323 [8.20] REF "BEFORE SHEAR"
-05	T-1S13-21-XX-2	.065 [1.65]	.090 ± .010 [2.29 ± .25] (SEE NOTE 5)	.080 [2.03] REF	.323 [8.20] REF "BEFORE SHEAR"
-06	T-1S13-02-XX-2	.126 [3.20]	.192 [4.88] REF	.100 [2.54] REF	.377 [9.58] REF

NOTES:

1. MAX. ALLOWABLE BOW: .005 IN/IN [mm/mm] AFTER ASSEMBLY.
2. MAX. PIN ROTATION IN BODY: 2°
3. PUSHOUT FORCE SHALL BE 1 lb MIN.
4. [C2] REPRESENTS A CRITICAL DIMENSION.
5. TAIL WILL BE SHEARED ON -04 & -05, REFERENCE TABLE 1.
6. MAX CUT FLASH .010 [.25].
7. MAX SHEAR BURR .003 [.08].
8. ORIENTATE PINS TO PREVENT BANDOLIER MARKS FROM SHOWING IN THE POST AREA. (SEE TABLE 3)
9. APPROVED FOR WAVE SOLDER APPLICATION ONLY.
10. RETAINING CLIP FOR -06 LEAD STYLE ONLY.

PROPRIETARY NOTE

THIS DOCUMENT CONTAINS INFORMATION CONFIDENTIAL AND PROPRIETARY TO SAMTEC INC. AND SHALL NOT BE REPRODUCED OR TRANSMITTED TO OTHER DOCUMENTS OR DISCLOSED TO OTHERS OR USED FOR ANY PURPOSE OTHER THAN THAT FOR WHICH IT WAS OBTAINED WITHOUT THE EXPRESS WRITTEN CONSENT OF SAMTEC INC.

MATERIAL:  
 BODIES:  
 LIQUID CRYSTAL POLYMER  
 COLOR: BLACK  
 TERMINALS:  
 PHOSPHOR BRONZE, ALLOY

**samtec**

EXISPROD\ASSEMBLY\2MM  
 TMM-ASM

520 PARK EAST BLVD. NEW ALBANY, INDIANA 47150  
 PHONE (812) 944-6733 P.O. BOX 1147  
 CODE 55322

MADE BY: REIDINGER 11-2-90

TMM-1XX-XX-XX-X-XX-XXX  
 SHEET 1 OF 2